

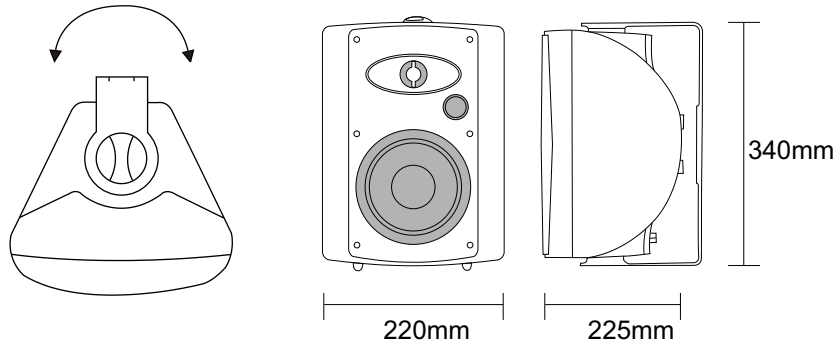

Wall Mount Speaker (Dampproof)

HC-540B



Model	HC-540B
Power Taps @100V	5W, 10W, 20W, 40W
Power Taps @70V	2.5W, 5W, 10W, 20W, 40W
Transformer Impedance	2K Ω /1K Ω /500 Ω /250 Ω /125 Ω
Input	70V/100V/8 Ω
SPL(1W/1M)	89dB
Max. SPL (Rated W/1M)	105dB
Frequency Response (-10dB)	100-20KHz
Finish	Baffle: ABS, Black/White Grille: Steel, Black/White
Speaker Driver	6" x 1.5" x 1"
Dimensions	340 x 220 x 225mm
Weight	4.1kg
Mounting	With mounting bracket fixed by screw