

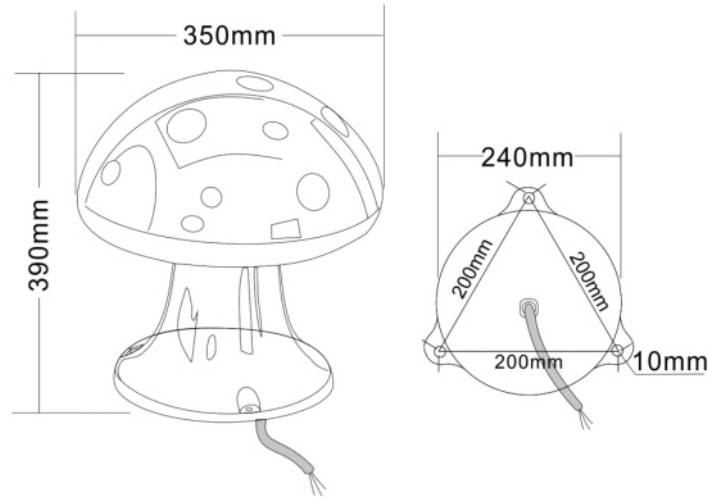

# Landscape Garden Speaker

## T-500H



### Specifications:

Model	T-500H
Power Taps @100V	25W, 50W
Power Taps @70V	12.5W, 25W
SPL(1W/1M)	95dB
Frequency Response (-10dB)	120-15KHz
Finish	Organic resin
Speaker Driver	2×4"+2.5"
IP Rate	IP66
Cutout Size	200 x 200 x 200mm
Dimensions(mm)	H: 390
Weight	5.49Kg